

NE555/NE556 – Timer IC

Overview

The 555 integrated circuit is a highly accurate timing circuit that is capable of producing both time delays or oscillation. The 556 device has two individual 555 timer circuits housed in a single package.

Pin Outs

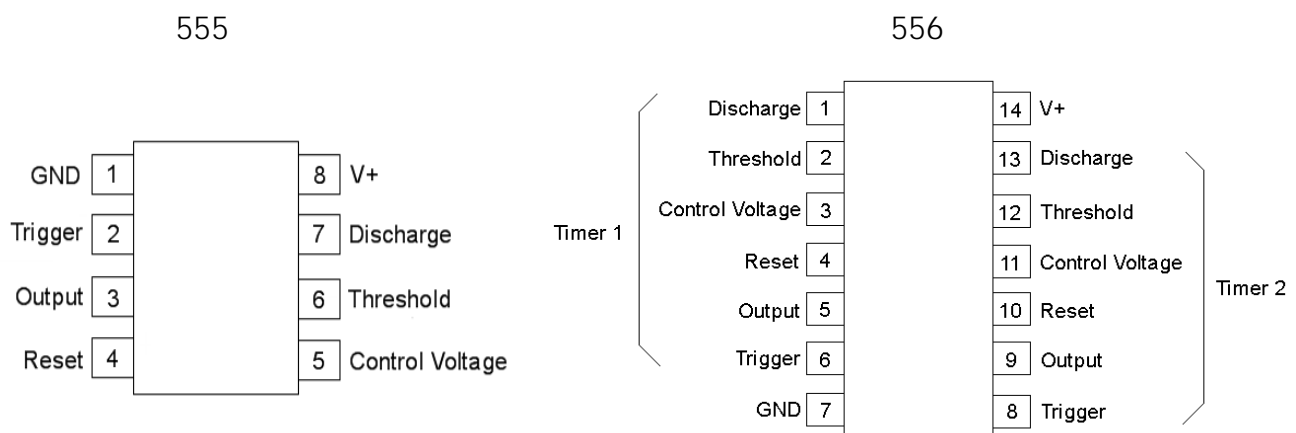

Pin Descriptions

V+	=	Supply voltage.
GND	=	Gnd (0V) connection for supply voltage.
Threshold charging	=	Active high input pin that is used to monitor the of the timing capacitor.
Control Voltage	=	Used to adjust the threshold voltage if required. This should be left disconnected if the function is not required. A 0.01uF capacitor to Gnd can be used in electrically noisy circuits.
Trigger	=	Active low trigger input that start the timer.
Discharge	=	Output pin that is used to discharge the timing capacitor.
Out	=	Timer output pin.
Reset	=	Active low reset pin. Normally connected to V+ if the reset function is not required.

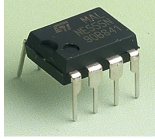

Block Diagram

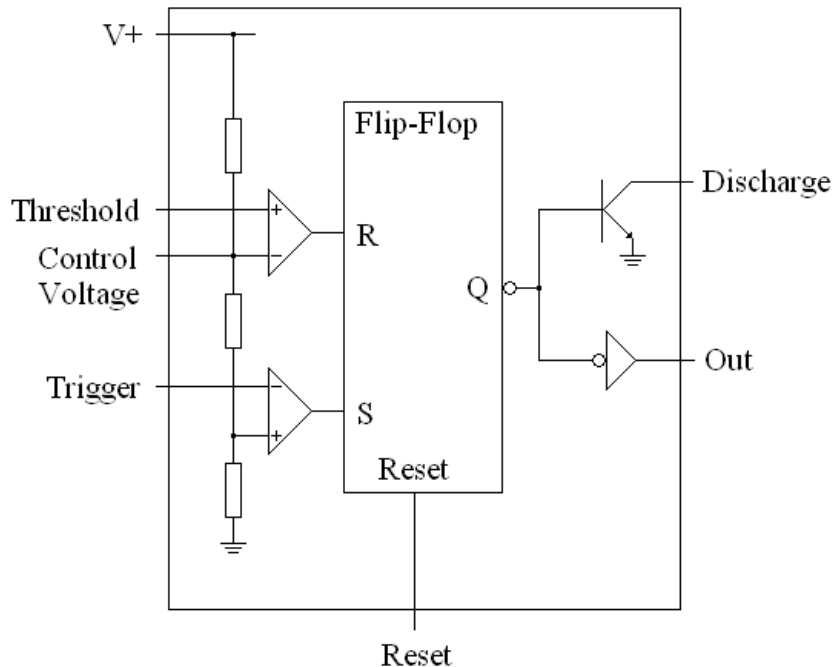

Operating Overview

The 555 timer is a simple circuit. By taking the trigger signal from high to low the flip-flop is set. This causes the output to go high and the discharge pin to be released from Gnd (0V). The releasing of the discharge pin from Gnd causes an external capacitor to begin charging.

When the capacitor is charges the voltage across it increases. This results in the voltage on the threshold pin increasing. When this is high enough it will result in the threshold pin to causing the flip-flop to reset.

This causes the output to go low and the discharge pin is also taken back to Gnd. This discharges the external capacitor ready for the next time the device is triggered.

Electrical Characteristics

Operating Voltage	= 4.5V to 16V
Maximum Supply Current	= 5mA @ 5V Operating Voltage = 12mA @ 15V Operating Voltage
High Level Output Voltage	= 3.3V @ 5V Operating Voltage = 13.3V @ 15V Operating Voltage
Maximum Output Current	= 200mA @ 15V Operating Voltage = 100mA @ 5V Operating Voltage

Environmental

Operating Temperature	= 0°C to 70°C
-----------------------	---------------

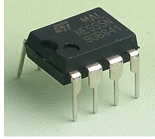

Monostable Operation

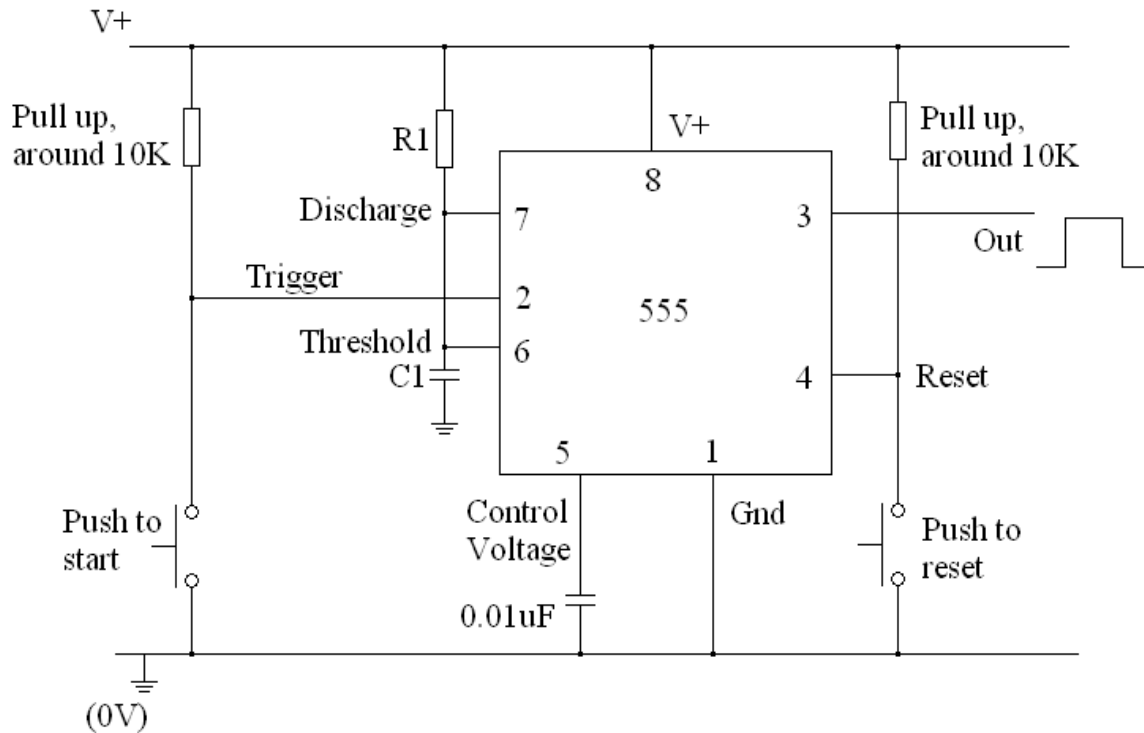

In monostable mode the device produces a 'one shot' pulsed output. The pulse is started by a taking the trigger input from a high (V+) to a low voltage. Once triggered the circuit remains in this state even if triggered again during the pulse interval.

The pulse high time is given by: $t = 1.1 \times R1 \times C1$

The high to low voltage transition on the trigger input causes the Flip-Flop to become set. This releases the short circuit (created by holding of the discharge pin low) across capacitor C1. At this point the output goes high. Capacitor C1 then begins to charge and the voltage across it begins to increase. When it reaches $2/3 V+$ the Flip-Flop is reset. This causes capacitor C1 to discharge very quickly and the output goes low.

Minimum output pulse = 5 μ s
Maximum output pulse = 5 minutes

R1 minimum resistance = 1K ohm
R1 maximum resistance = 1Mohm

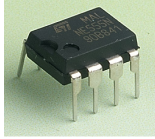

Astable Operation

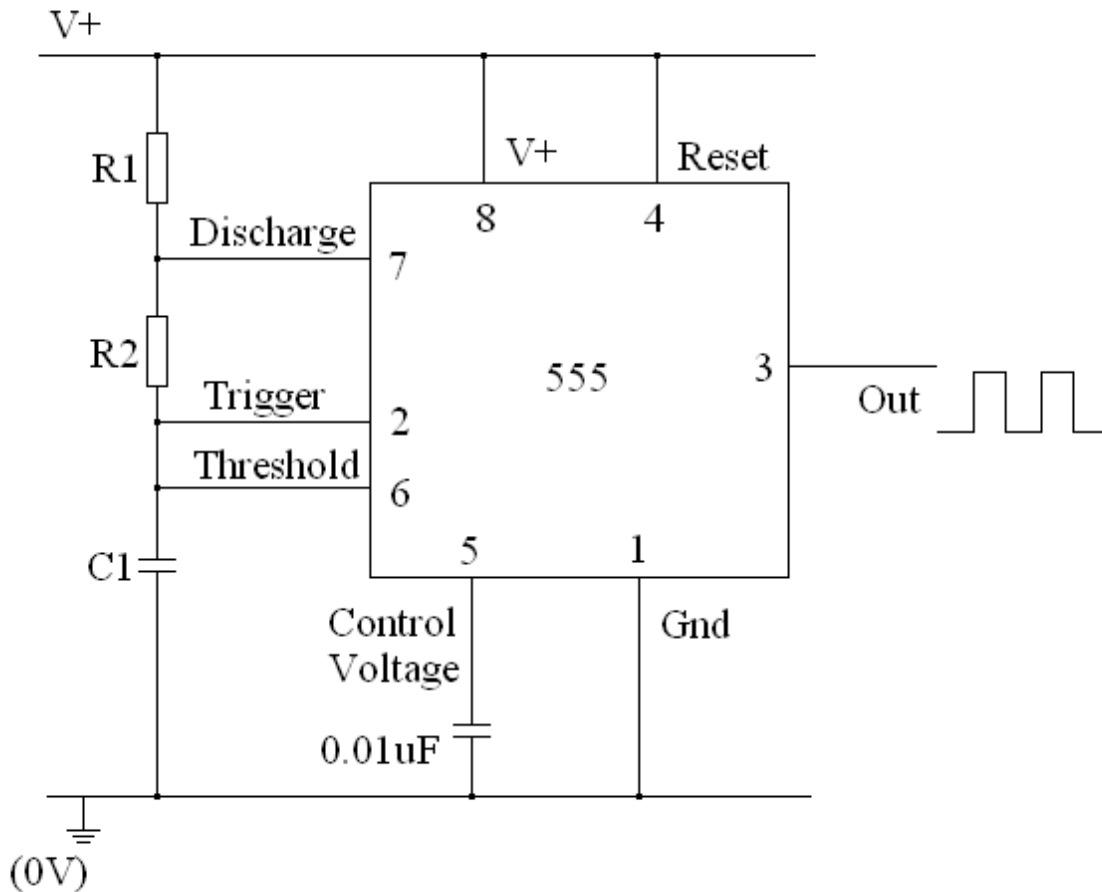

In astable mode the timer continually triggers itself and runs as a multi vibrator. This results in a continually repeating signal being generated on the output pin.

The external capacitor C1 charges through both R1 and R2 but discharges only through R2. Therefore the duty cycle is determined by the ratio of these resistors. If the value of the two resistors is the same the duty cycle will be 50% and a square wave will be output.

The 'High' output time is given by: $t_1 = 0.693 (R_1 + R_2) \times C_1$

The 'Low' output time is given by: $t_2 = 0.693 (R_2) \times C_1$

Therefore the total period is given by: $T = t_1 + t_2 = 0.693 (R_1 + R_2) \times C_1$

The frequency of oscillation is given by: $f = 1 / T = 1.44 / ((R_1 + R_2) \times C_1)$